

L20-CS8421-microcodeHW

Microcode Homework

CS8421

Computing Systems

Dr. Ken Hoganson

Class

Will

Start

Momentarily...

Two homework problems included:

1. Write microcode instructions for the machine we discussed in lecture
2. Create microcode instruction format and control codings for specified machine.

Contains

- control codes and example microcode from previous lecture.
- One page assignment using class machine.
- One page assignment with new machine.

- Control codings:
- For each device, we need to specify the interpretation or meaning. Examples:
- AMUX
 - 0 – from A latch
 - 1 – from MDR
- CMUX
 - 0 – from C bus
 - 1 – from MDR
- MAR-MUX
 - 0 – from C bus
 - 1 – from B bus

- Condition Codes
 - ZN
 - 00 – no jump
 - 01 – jump if outcome is negative
 - 10 – jump if outcome is zero
 - 11 – unconditional jump, rather than jump if negative or zero
- ALU
 - 00 – pass through A bus, no operation
 - 01 – ADD
 - 10 – AND
 - 11 – complement
- SHIFT
 - 00 – pass through A bus, no operation
 - 01 – SHR
 - 10 – SHL
 - 11 – undefined (perhaps a rotate?)

- Also need to specify register codings (number them as expected)
- 00000 – 01111, 0 – F
- PC: 11111
- IR: 11110
- Note that there are 14 unused codings, which could be useful for some other purpose, perhaps for hardcoding special values, like +1 or –1 for incrementing and decrementing
- +1: 10001
- 0: 10000

To fetch the next instruction, we have to do:

- $MAR \leftarrow PC, \quad PC \leftarrow PC + 1$

PC to b bus, +1 to a bus

ALU add, SHFT do nothing

MAR from b bus

C mux from c bus/alu/shift

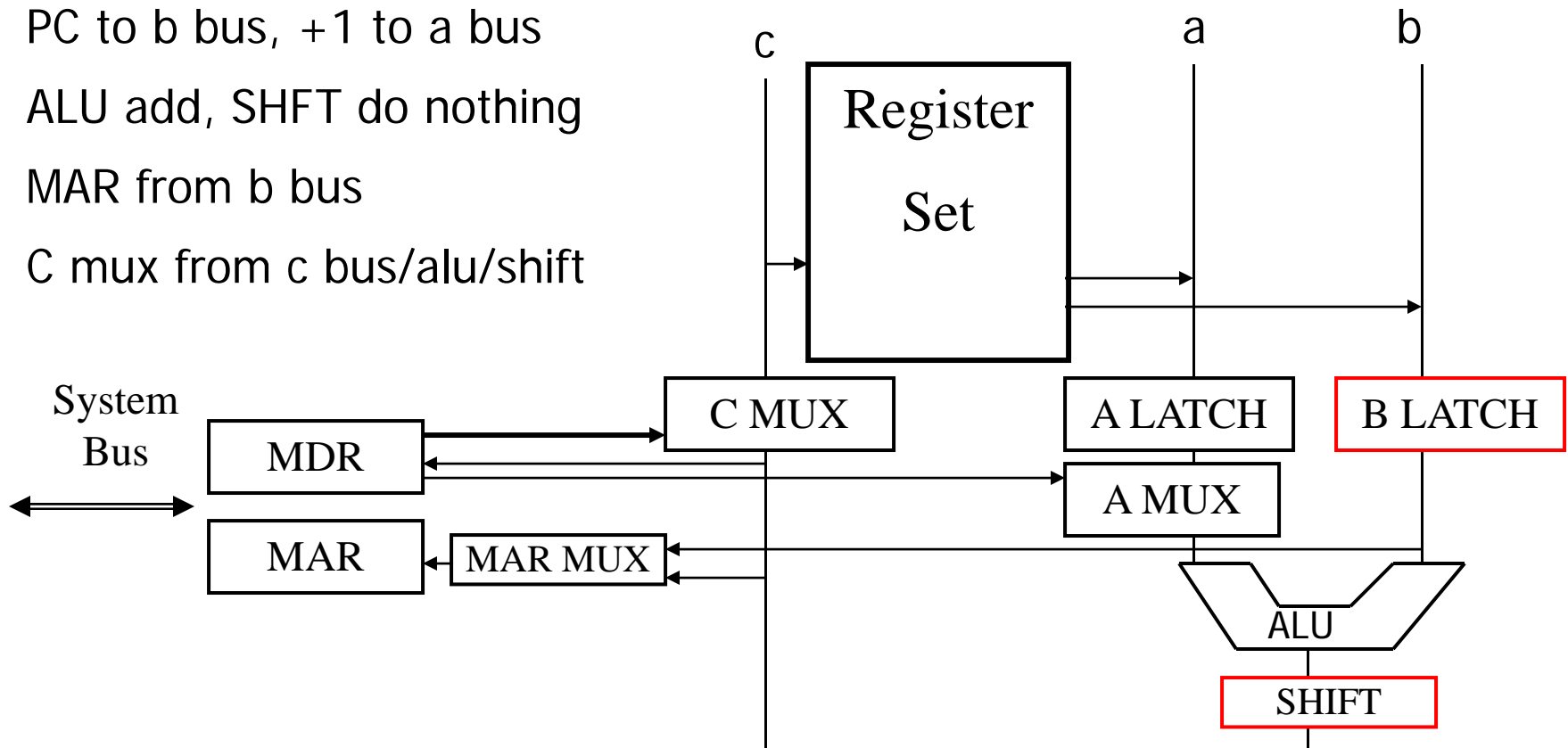

To fetch the next instruction, we have to do:

- $MAR \leftarrow PC$
- $PC \leftarrow PC + 1$

muxes

A	C	MAR	COND	ALU	SHFT	MAR	MDR	A bus	B bus	C bus	micro-address
0	0	1	00	01	00	1	0	10001	11111	11111	XXXXXXXXX

Write microcode instructions for this machine that will:

- ADD register 5 and 7, and put the result in register 3
- Subtract register 2 from register 3, result in register 3

muxes

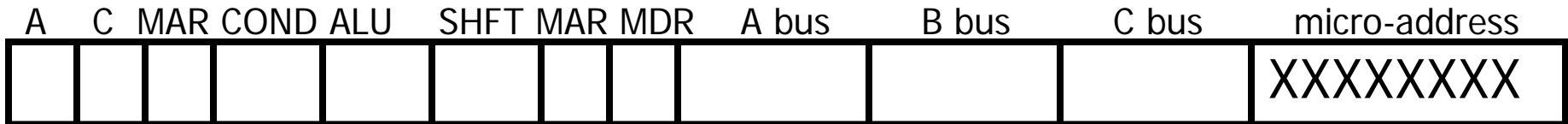

- For the following architecture, develop a microcode instruction format using the techniques illustrated in this lecture. 32 registers total in register set. Specify the control codes for each device.

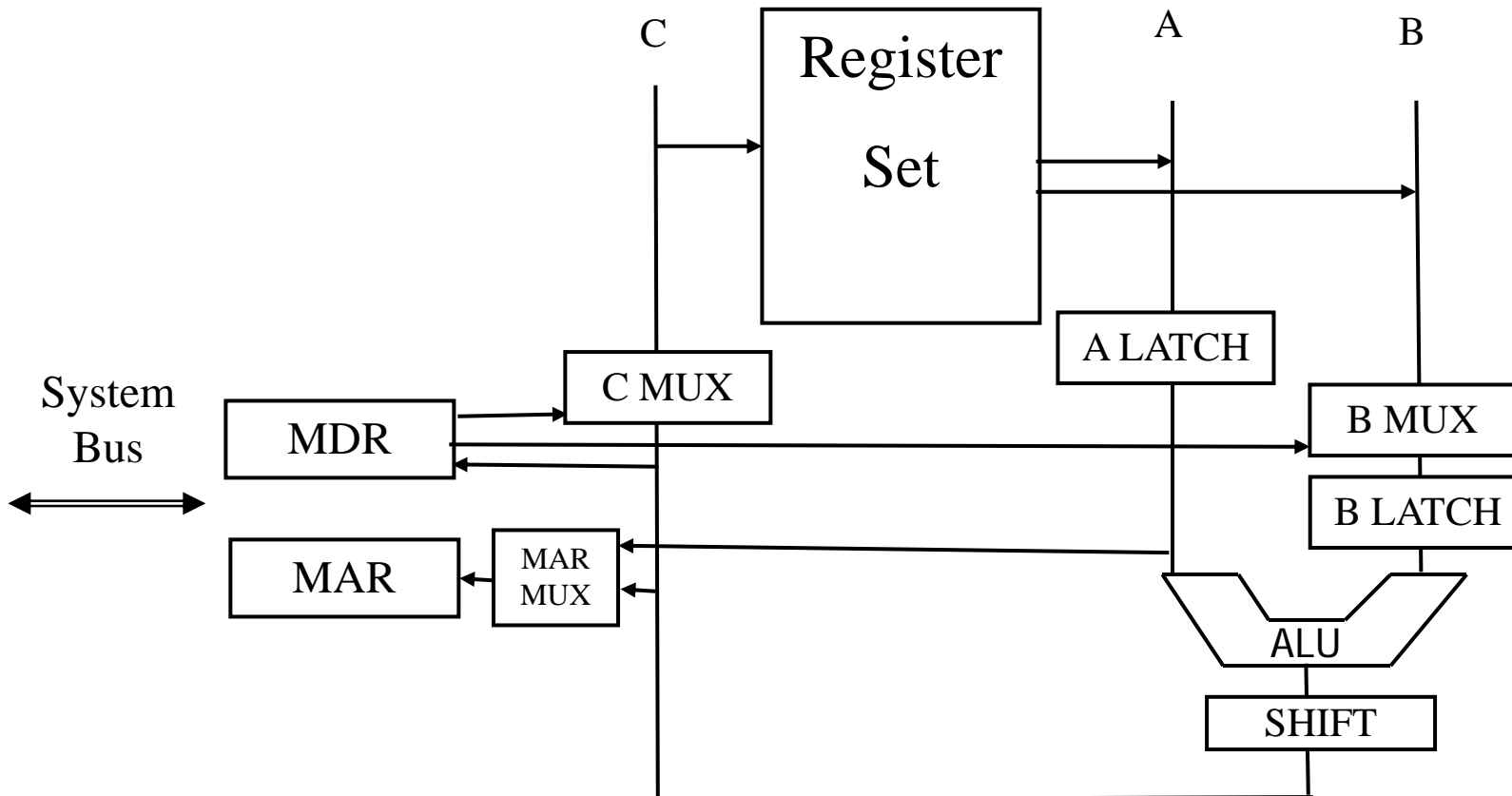

**End
Of
Today's
Lecture.**

